

ASSEMBLY INSTRUCTIONS

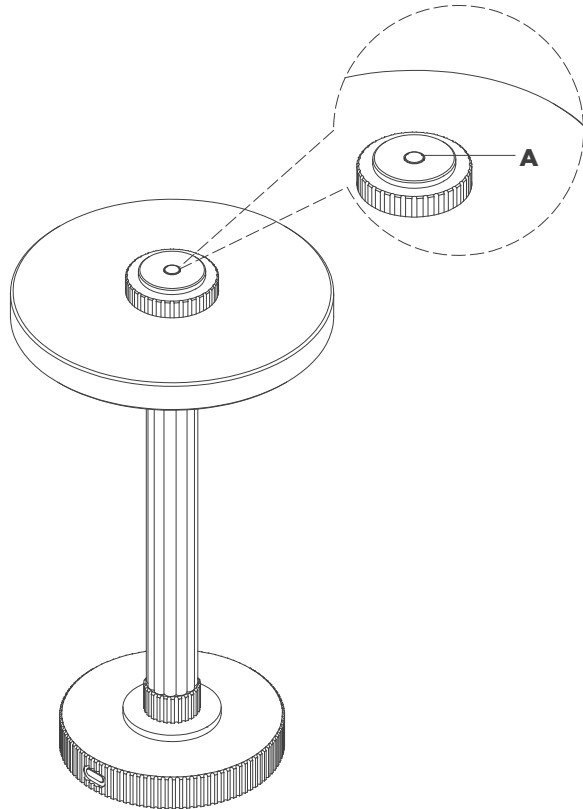

Una Accent Lamp

Item # S 3150

NOTICE:

Inspect item carefully before attempting to install. If there is any damage or obvious defect, do not install. Item may not be returned once it has been installed.

1. Carefully remove all parts from the box. Place on a clean, soft surface.
2. For best results fully charge battery before use.
3. Test the lamp.
Dimmer switch operation: Touch dimmer **(A)** to adjust between high, medium, low and off settings.
4. Installation is complete.

Charging Instructions: Charge lamp using provided USB-C cord. Plug located at base.

Note: For convenience, USB-C to USB-A adapter and charging plug is included.



USB TYPE C

USB TYPE A

Care Instructions:

1. Clean only with a soft dry cloth or feather duster. Do not use abrasive or chemical agents.
2. Battery disposal should be in compliance with any local regulations that address the disposal of hazardous materials and the following or equivalent: "Do not incinerate."

ASSEMBLY INSTRUCTIONS

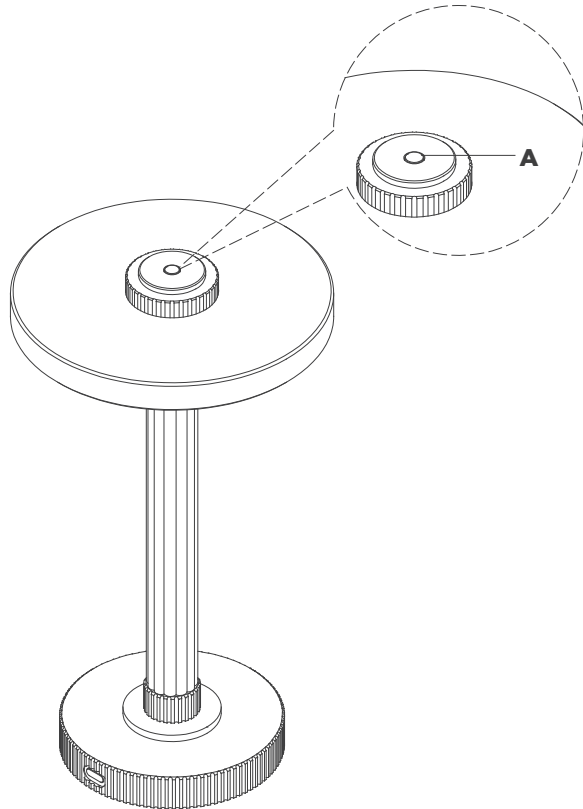

Una Accent Lamp

Item # S 3150

NOTICE:

Inspect item carefully before attempting to install. If there is any damage or obvious defect, do not install. Item may not be returned once it has been installed.

FCC Statement

This device complies with part 15 of the FCC Rules. Operation is subject to the following two conditions: (1) This device may not cause harmful interference, and (2) this device must accept any interference received, including interference that may cause undesired operation.

Note: This equipment has been tested and found to comply with the limits for a Class B digital device, pursuant to part 15 of the FCC Rules. These limits are designed to provide reasonable protection against harmful interference in a residential installation. This equipment generates, uses and can radiate radio frequency energy and, if not installed and used in accordance with the instructions, may cause harmful interference to radio communications. However, there is no guarantee that interference will not occur in a particular installation. If this equipment does cause harmful interference to radio or television reception, which can be determined by turning the equipment off and on, the user is encouraged to try to correct the interference by one or more of the following measures:

- Reorient or relocate the receiving antenna.
- Increase the separation between the equipment and receiver.
- Connect the equipment into an outlet on a circuit different from that to which the receiver is connected.
- Consult the dealer or an experienced radio/TV technician for help.

ASSEMBLY INSTRUCTIONS

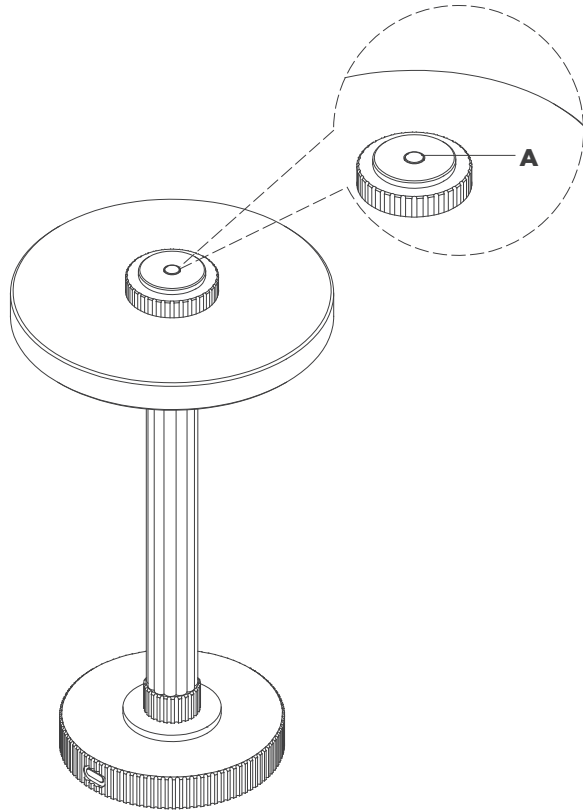

Una Accent Lamp

Item # S 3150

NOTICE:

Inspect item carefully before attempting to install. If there is any damage or obvious defect, do not install. Item may not be returned once it has been installed.

Any changes or modifications to this unit not expressly approved by the party responsible for compliance could void the user's authority to operate the equipment.

Supplier's Declaration of Conformity
47 CFR § 2.1077 Compliance Information